

# QUICK-CHANGE TRAPS

# Universal Style Steam Traps

(Universal Style Connectors and Universal Trap Modules)

Universal Style Steam Traps feature a permanent installation of the Universal Connector with a 2-bolt mounting arrangement for the Universal Steam Trap Module, allowing the Steam Trap to be removed and replaced in minutes

- ◆ without having to unthread piping
- ◆ by removing only 2-bolts with a socket or open-end wrench

**7 different connectors • 6 different trap modules**

**Thermodynamic • Thermostatic • Inverted Bucket • Bi-Metallic • Float & Thermostatic**

**Any Universal Connector will work with any Universal Steam Trap Module**

Model	<b>WU450</b>
Sizes	<b>1/2", 3/4", 1"</b>
Connections	<b>NPT, SW, FLG</b>
Body Material	<b>Stainless Steel</b>
PMO Max. Operating Pressure	<b>(trap module dependent)</b>
TMO Max. Operating Temperature	<b>(trap module dependent)</b>
PMA Max. Allowable Pressure	<b>750 PSIG @ 100°F</b>
TMA Max. Allowable Temperature	<b>800°F @ 400 PSIG</b>



*see following page for connector variations.*

**Universal Style Steam Traps** are recommended in any application, – particularly those which require simple and frequent replacement of steam traps

**Select a Trap Module for your application**

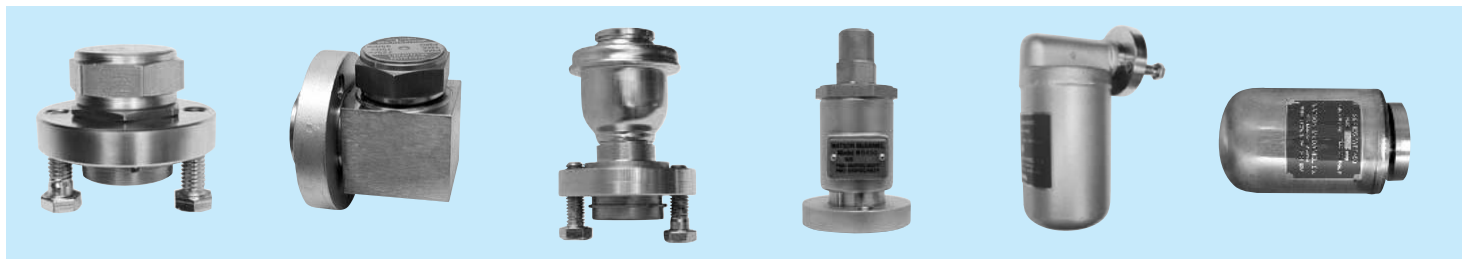

**WD450  
WD450L**  
Thermodynamic  
"Top Mount"

**WD450SM  
WD600LSM  
WD600LSM-HP**  
Thermodynamic  
"Side Mount"

**WT450**  
Thermostatic

**WB450**  
Bi-Metallic

**WSIB450  
WSIB450H**  
Inverted Bucket

**WFT450**  
Float & Thermostatic

# QUICK-CHANGE TRAPS

# Universal Style Steam Traps

(Universal Style Connectors and Universal Trap Modules)

**It all adds up.... a Universal Style Connector + a Universal Trap Module = the most convenient, time-efficient & cost effective solution to maintaining your steam traps.**

**STEP 1:** Select an appropriate Universal **STEAM TRAP MODULE** (shown below) for your application. Consult following pages for Steam Trap details.

**STEP 2:** Select appropriate Universal **CONNECTOR**. Any connector shown below will work with any Universal Steam Trap Module (including those of other manufacturers).

**STEP 3:** Order configured Universal Style Steam Traps.

## UNIVERSAL TRAP MODULES



**WD450  
WD450L  
Thermodynamic  
"Top Mount"**  
*Only recommended for  
Horizontal Piping  
Installations*



**WD450SM  
WD450LSM  
WD600LSM-HP  
Thermodynamic  
"Side Mount"**



**WT450  
Thermostatic**



**WB450  
Bi-Metallic**



**WSIB450  
WSIB450H  
Inverted Bucket**

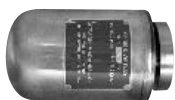

**WFT450  
Float &  
Thermostatic**

## UNIVERSAL CONNECTORS



**WU450  
No Strainer**



**WU450S  
Strainer**



**WU450SB  
Strainer &  
Blowdown**



**WU450S-LR  
Strainer**



**WU450SB-LR  
Strainer &  
Blowdown**



**WU450S-RL  
Strainer**



**WU450SB-RL  
Strainer &  
Blowdown**

## FEATURES

- 2-bolt mounting allows Trap Module to be removed and replaced without having to unthread piping
- Trap module can swivel 360° on the universal connector allowing proper orientation
- Compatible with other manufacturers trap modules
- All stainless steel construction
- Flange connections available for connector

*Models WU450-LR (left to right flow as viewed) are Standard.*

*Models WU450-RL Connectors were made available for situations where problems occur due to obstructions or trap mounting orientation.*

## UNIVERSAL STYLE STEAM TRAPS

# Universal Style Steam Traps

(Universal Style Connectors and Universal Trap Modules)

Universal Connectors are used in steam systems to simplify the replacement and maintenance of Steam Traps.

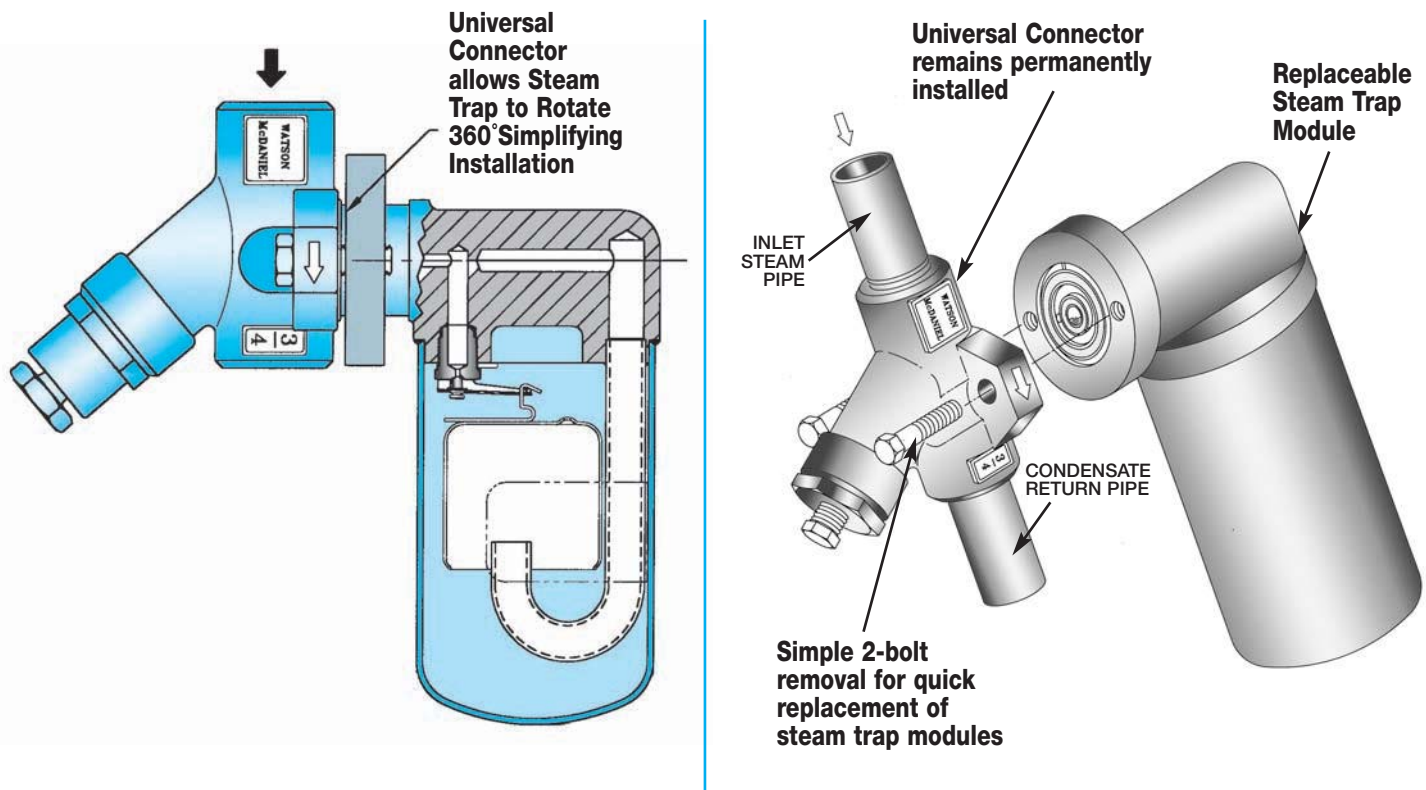

**Universal Connectors allow Steam Traps to be removed and replaced in minutes without having to unthread piping.**

**Two bolts** connect the steam trap module to the permanently-installed universal connector, allowing the trap module to be quickly and easily removed and replaced using an open-end or socket wrench. **Universal Style Steam Traps** are commonly used in chemical plants, petrochemical refineries, paper mills and most other industrial facilities. Watson McDaniel's WU450 connectors conform to industrial standards, making them compatible with other manufacturers' universal steam trap modules.

Watson McDaniel recommends using the Universal Style Steam Traps in any application, in particular those which require frequent maintenance or replacement of steam traps.

- **Universal style steam traps with 2-bolt mounting allows for fast, easy replacement of trap module, making it more cost-effective than replacing conventional type steam traps**
- **All stainless steel construction**
- **Trap module can swivel 360° on the universal connector allowing any orientation during installation**
- **These universal connectors are compatible with most other manufacturer's trap modules**
- **Universal connectors are available with integral strainer and blowdown valve**

# UNIVERSAL STYLE STEAM TRAPS

## WU450 Series

### Universal Connectors for Universal Steam Trap Modules

Watson McDaniel reserves the right to change the designs and/or materials of its products without notice.  
©2010 Watson McDaniel Company

Model	<b>WU450, WU450S, WU450SB WU450S-LR, WU450SB-LR, WU450S-RL, WU450SB-RL</b>
Sizes	<b>1/2", 3/4", 1"</b>
Connections	<b>NPT, SW, FLG</b>
Body Material	<b>Stainless Steel</b>
PMO Max. Operating Pressure	<b>(trap module dependent)</b>
TMO Max. Operating Temperature	<b>(trap module dependent)</b>
PMA Max. Allowable Pressure	<b>750 PSIG @ 100°F</b>
TMA Max. Allowable Temperature	<b>800°F @ 400 PSIG</b>

Steam Trap Modules that mount to Universal Connectors are shown on the following pages. Trap modules available in: Inverted Bucket, Float & Thermostatic, Thermodynamic, Thermostatic and Bi-metallic type.

### TYPICAL APPLICATIONS

**DRIP, TRACER:** The **WU450 Series** Universal Connectors are used in steam systems where a simplified and economical maintenance program of steam traps is desired. These universal connectors can be used for drip service on steam mains and steam supply lines, tracing, or small process equipment. Industrial standard 2-bolt universal connectors are commonly used in chemical plants, petrochemical refineries, paper mills and other industrial facilities. The WU450 connectors conform to industrial standards, making them compatible with other manufacturers' universal steam trap modules.

#### Used with the following Watson McDaniel Steam Trap Modules:

- WSIB450** - Inverted Bucket
- WD450** - Thermodynamic
- WD450SM** - Thermodynamic
- WD600LSM** - Thermodynamic
- WT450** - Thermostatic
- WFT450** - Float & Thermostatic
- WB450** - Bi-Metallic

### HOW IT WORKS

WU450 universal connectors remain permanently installed in the piping system. The convenient 2-bolt mounting system allows the trap module to be replaced quickly and easily using a socket or open-end wrench.

### FEATURES

- Universal connector with 2-bolt mounting allows for fast, easy replacement of trap module making it more cost-effective than replacing conventional type steam traps
- All stainless steel construction
- Trap module can rotate 360° on the universal connector allowing any orientation during installation
- Compatible with most other manufacturers' trap modules
- Available with integral strainer and blowdown valve

### SAMPLE SPECIFICATION

The Universal Connector shall be all stainless steel construction with a two-bolt 360 degree swivel mount flange design and available with integral strainer and blowdown valve.



**WU450**  
no strainer



**WU450S**  
with strainer

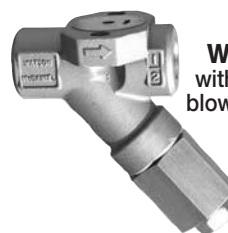

**WU450SB**  
with strainer & blowdown valve



**WU450S-LR**  
with strainer  
(Flow direction  
Left to Right)



**WU450S-RL**  
with strainer  
(Flow direction  
Right to Left)



**WU450SB-LR**  
with strainer & blowdown valve  
(Flow direction  
Left to Right)



**WU450SB-RL**  
with strainer & blowdown valve  
(Flow direction  
Right to Left)

Note: Optional Flanged units available.

### INSTALLATION

The universal connector can be installed in any position. Installation should include isolation valves.

### MAINTENANCE

The strainer should be periodically cleaned by removal or use of the optional blowdown valve. For full maintenance details see Installation and Maintenance Manual.

### MATERIALS

Body	Stainless Steel, AISI 316
Strainer	40 Mesh Stainless Steel, AISI 304
Blowdown Valve	Stainless Steel, AISI 303

### HOW TO SIZE/ORDER

Specify universal connector. See following pages for Steam Trap Modules.

# UNIVERSAL STYLE STEAM TRAPS

## WU450 Series

### Universal Connectors - Dimensions

Watson McDaniel reserves the right to change the designs and/or materials of its products without notice.  
©2010 Watson McDaniel Company

**WU450, WU450S, WU450SB, Universal Connectors**  
Connectors available in 1/2", 3/4" and 1" sizes in NPT or Socket-Weld Connections

Note: Optional Flange units available.

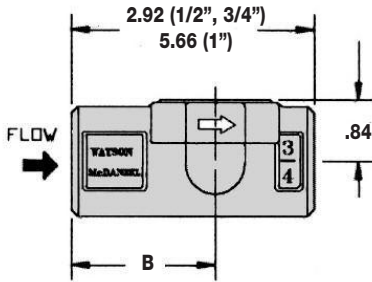

**WU450**  
(No Strainer)

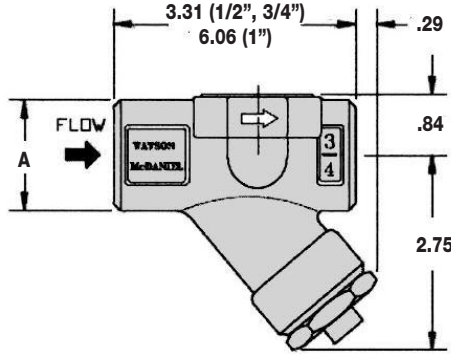

**WU450S**  
(Strainer)

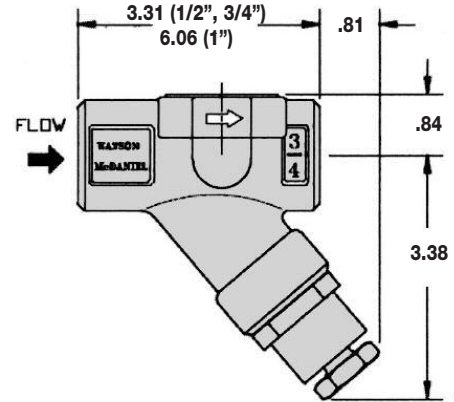

**WU450SB**  
(Strainer & Blowdown)

DIMENSIONS - inches		
Size	A	B
1/2"	1.50	1.97
3/4"	1.50	1.97
1"	1.75	3.35

# UNIVERSAL STYLE STEAM TRAPS

## WU450 Series

### Universal Connectors - Dimensions

#### WU450S-LR & WU450SB-LR Universal Connectors

Connectors available in 1/2", 3/4" and 1" sizes in NPT or Socket-Weld Connections

Note: Optional Flange units available.

Flow Direction - LEFT TO RIGHT

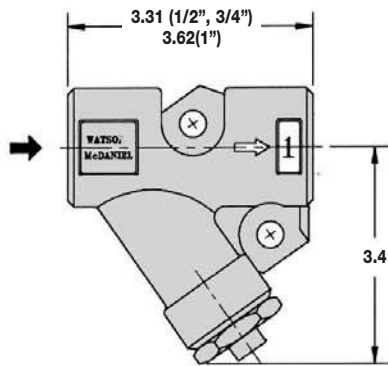

WU450S-LR  
(Strainer)

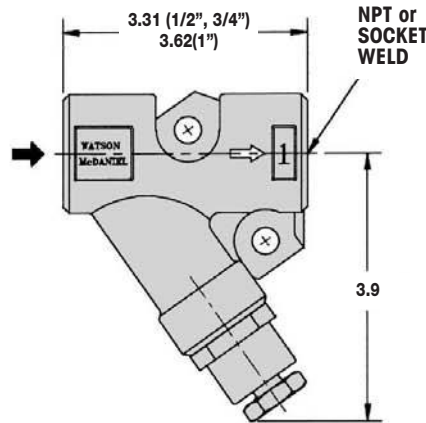

WU450SB-LR  
(Strainer & Blowdown)

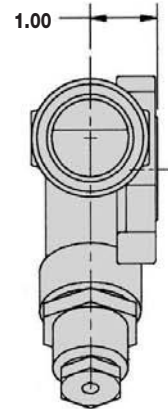

#### WU450S-RL & WU450SB-RL Universal Connectors

Connectors available in 1/2", 3/4" and 1" sizes in NPT or Socket-Weld Connections

Note: Optional Flange units available.

Flow Direction - RIGHT TO LEFT

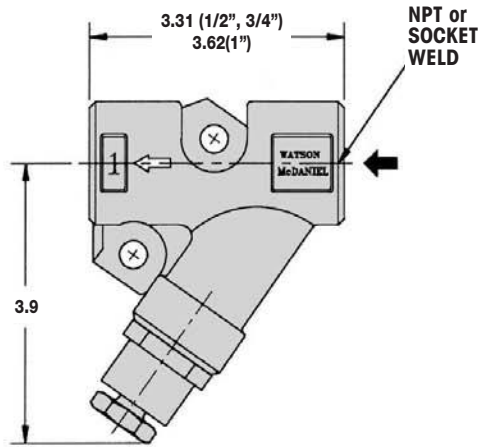
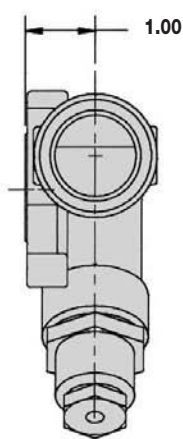

WU450SB-RL  
(Strainer & Blowdown)

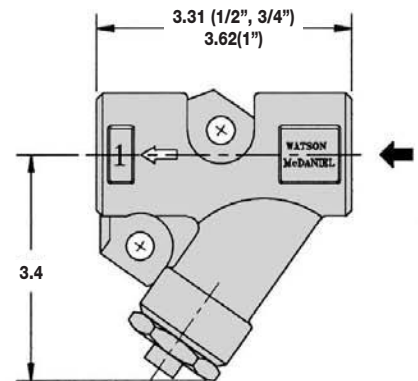

WU450S-RL  
(Strainer)

# UNIVERSAL STYLE STEAM TRAPS

## WSIB450

Watson McDaniel reserves the right to change the designs and/or materials of its products without notice.  
©2010 Watson McDaniel Company

Inverted Bucket **Steam Trap Module** (mounts to Universal Connectors)

Model	<b>WSIB450, WSIB450H</b>
Connections	<b>Fits WU450 Series universal connectors</b>
Body Material	<b>Stainless Steel</b>
PMO Max. Operating Pressure	<b>450 PSIG*</b>
TMO Max. Operating Temperature	<b>800°F</b>
PMA Max. Allowable Pressure	<b>720 PSIG @ 100°F</b>
TMA Max. Allowable Temperature	<b>800°F @ 400 PSIG</b>

\*750°F @ operating pressures below 400 PSIG. See installation note regarding using trap in superheated applications.

**Steam trap modules can be used with other manufacturers' Universal Connectors.**



**WSIB450  
Inverted Bucket  
Steam Trap  
Module**

### TYPICAL APPLICATIONS

**DRIP, TRACER:** The **WSIB450** inverted bucket steam trap module, mounted to a universal connector, is typically used for drip and tracing applications. Also used on process equipment with light loads and where air removal is not critical. The WSIB450 trap module mounts to any universal connector.

### HOW IT WORKS

The universal connector is permanently installed into the pipeline where the steam trap would normally be placed. The trap module is bolted to the universal connector with two bolts and sealed with a gasket. When a new trap module is needed, it can be easily removed and replaced with a standard open-end or socket wrench without disturbing the existing piping.

### SAMPLE SPECIFICATION

The steam trap shall be an all stainless steel modular design, inverted bucket type with a frictionless valve lever assembly. The trap shall have a 360 degree swivel mount on a stainless steel Universal Connector that is available with integral strainer and blowdown valve options.

### INSTALLATION & MAINTENANCE

Trap module must be installed in orientation shown. Installation should include isolation valves. With superheated steam, a check valve must be installed at inlet of trap. For full maintenance details, see Installation and Maintenance Manual.

### OPTIONS

Universal Connectors are available with an integral strainer and blowdown valve. Connector is purchased separately. See the WU450 Universal Connectors section for more information.

### FEATURES

- Trap module can be easily removed and replaced in minutes without having to disconnect any piping
- Hardened stainless steel valves and seat
- Freeze resistant
- Connectors available with integral strainers and blowdown valves
- 360° swivel design for convenient installation

### MATERIALS

Body	Stainless Steel GR CF3
Cover	304L Stainless Steel
Internals	300 Series Stainless Steel
Valve Plug & Seat	420F Stainless Steel
Bolts	ASTM A193 GR B7
Gasket	Spiral-Wound 304 Stainless Steel with Grafoil Filler
Swivel Flange	303 Stainless Steel

### CAPACITIES – Condensate (lbs/hr)

Model	Orifice Size	PMO (PSIG)	Differential Pressure (PSI)																																							
			5	10	15	20	25	30	40	50	60	70	80	100	125	150	180	200	250	350	450																					
WSIB450-20	3/16"	20	450	560	640	690																																				
WSIB450-80	1/8"	80	300	350	400	440	460	500	550	580	635	660	690																													
WSIB450-150	#38	150	210	250	280	300	320	350	380	400	420	450	470	500	550	570																										
WSIB450-450	.057	450	31	50	70	84	95	105	120	133	145	152	160	174	187	198	208	215	228	248	263																					
WSIB450H-15	1/4"	15	830	950	1060																																					
WSIB450H-30	3/16"	30	530	700	820	880	950	1000																																		
WSIB450H-70	5/32"	70	380	500	560	620	680	710	770	840	900	950																														
WSIB450H-125	1/8"	125	285	375	440	485	530	560	620	670	720	780	800	860	950																											
WSIB450H-200	7/64"	200	205	265	315	350	385	410	465	500	580	590	620	650	700	810	840	860																								
WSIB450H-250	#38	250	155	205	240	270	295	320	360	400	500	530	550	580	630	660	690	710	760																							
WSIB450H-450	.057	450	31	50	70	84	95	105	120	133	145	152	160	174	187	198	208	215	228	248	263																					

# UNIVERSAL STYLE STEAM TRAPS

# WFT450

Float & Thermostatic **Steam Trap Module** (mounts to Universal Connectors)

Model	<b>WFT450</b>
Connections	<b>Fits WU450 Series universal connectors</b>
Body Material	<b>Stainless Steel</b>
PMO Max. Operating Pressure	<b>225 PSIG</b>
TMO Max. Operating Temperature	<b>397°F</b>
PMA Max. Allowable Pressure	<b>720 PSIG @ 100°F</b>
TMA Max. Allowable Temperature	<b>800°F @ 400 PSIG</b>



**WFT450**  
Float & Thermostatic  
Steam Trap Module

**Steam trap modules can be used with other manufacturers' Universal Connectors.**

## TYPICAL APPLICATIONS

**PROCESS, DRIP:** The **WFT450** Float & Thermostatic trap module mounted to a universal connector, is typically used on process equipment that generate light condensate loads and require excellent air handling capabilities. These low capacity float & thermostatic trap modules can also be used in drip service on steam mains, tracer systems and steam supply lines. The WFT450 trap module mounts to any universal connector.

## HOW IT WORKS

The universal connector is permanently installed into the pipeline where the steam trap would normally be placed. The trap module is bolted to the universal connector with two bolts and sealed with a gasket. When a new trap module is needed, it can be easily removed and replaced with a standard open-end or socket wrench without disturbing the existing piping.

## SAMPLE SPECIFICATION

The steam trap shall be an all stainless steel modular design, float & thermostatic unit. The thermostatic air vent to be pressure balanced welded bellows. The trap shall have a 360 degree swivel mount on a stainless steel Universal Connector that is available with integral strainer and blowdown valve options.

## INSTALLATION & MAINTENANCE

Trap module must be installed in orientation shown. Installation should include isolation valves. For full maintenance details, see Installation and Maintenance Manual.

## OPTIONS

Universal Connectors are available with an integral strainer and blowdown valve. Connector is purchased separately. See the Universal Connectors section for more information.

## FEATURES

- Trap module can be easily removed and replaced in minutes without having to disconnect any piping
- Hardened stainless steel valves and seat
- Freeze resistant
- Connectors available with integral strainers and blowdown valves
- 360° swivel design for convenient installation

## MATERIALS

Body	Stainless Steel GR CF3
Cover	304L Stainless Steel
Internals	300 Series Stainless Steel
Valve Disc	420F Stainless Steel
Valve Seat	17-4 PH Stainless Steel
Bolts	ASTM A193 GR B7
Gasket	Spiral-Wound 304 Stainless Steel with Grafoil Filler
Swivel Flange	303 Stainless Steel

## CAPACITIES – Condensate (lbs/hr)

Model	PMO (PSIG)	Differential Pressure (PSI)																		
		1/4	1/2	1	2	5	10	15	20	30	40	50	65	75	100	125	145	200	225	
WFT450-15	15	390	490	620	780	1050	1320	1500												
WFT450-65	65	115	155	205	270	390	520	610	685	810	910	995	1110							
WFT450-145	145	55	75	100	135	200	270	320	365	435	490	540	600	640	725	795	850			
WFT450-225	225	40	50	70	95	135	185	220	245	290	330	360	405	430	485	530	565	645	680	



# UNIVERSAL STYLE STEAM TRAPS

## WD450 & WD450SM

Watson McDaniel reserves the right to change the designs and/or materials of its products without notice.  
©2010 Watson McDaniel Company

Thermodynamic **Steam Trap Module** (mounts to Universal Connectors)

Model	<b>WD450SM, WD450LSM</b> (Side Mount Style) <b>WD450, WD450L</b> (Top Mount Style)
Connections	<b>Fits WU450 Series Universal Connectors</b>
Body Material	<b>Stainless Steel</b>
PMO Max. Operating Pressure	<b>450 PSIG</b>
TMO Max. Operating Temperature	<b>750°F</b>
PMA Max. Allowable Pressure	<b>720 PSIG @ 100°F</b>
TMA Max. Allowable Temperature	<b>800°F @ 400 PSIG</b>



**WD450SM**  
**Thermodynamic Steam Trap Module**  
(Side Mount Style)  
For vertical or horizontal piping installations.



**WD450**  
**Thermodynamic Steam Trap Module**  
(Top Mount Style)  
Recommended for horizontal piping installations only so that cap can be oriented upwards as shown.

Steam trap modules can be used with other manufacturers' Universal Connectors.

### TYPICAL APPLICATIONS

**DRIP, TRACER:** The **WD450SM & WD450** steam trap modules mounted to a universal connector can be used anywhere conventional thermodynamic steam traps are used. Used on drip, tracing and light process applications where removal of air is not critical. The **WD450 & WD450SM** trap modules mount to any Universal Connector. The **WD450** is recommended for horizontal piping only so that cap can be oriented upwards, as shown.

### HOW IT WORKS

The universal connector is permanently installed into the pipeline where the steam trap would normally be placed. The trap module is bolted to the universal connector with two bolts and sealed with two gaskets. When a new trap module is needed, it can be easily removed and replaced with a standard open-end or socket wrench without disturbing the existing piping.

### FEATURES

- Trap module can be easily removed and replaced in minutes without having to disconnect any piping
- Trap modules can be used with most manufacturers' 2-bolt universal connector
- All stainless steel construction with hardened seat

### SAMPLE SPECIFICATION

The steam trap module shall be designed to attach to the industry standard two-bolt universal connector. Trap module shall be of a thermodynamic design. Universal connector shall conform to the two bolt industry standard with integral strainer and blowdown options.

### INSTALLATION

Trap module must be installed in orientation shown. Isolation valves should be installed before and after the universal connector to facilitate maintenance. Trap module is attached to the connector using two bolts and two sealing gaskets.

### MAINTENANCE

If the trap fails for any reason, replace only the trap module. If universal connector is equipped with an integral strainer it should be cleaned periodically. For full maintenance details see Installation and Maintenance Manual.

### OPTIONS

Universal Connectors are available with an integral strainer and blowdown valve. Connector is purchased separately. See the Universal Connectors section for more information.

### MATERIALS

Body	Stainless Steel, AISI 420
Disc	Stainless Steel, AISI 420
Cap	Stainless Steel, AISI 416
Insulation Cover	Stainless Steel, AISI 304
Bolts	Steel, ASTM A193 GR B7
Gaskets (2)	Spiral Wound 304 Stainless Steel with Grafoil Filler

### CAPACITIES – Condensate (lbs/hr)

Model	Differential Pressure (PSI)																
	4	10	15	20	25	30	40	50	75	100	150	200	250	300	350	400	450
WD450L WD450LSM	140	215	242	270	295	320	355	390	455	510	600	670	730	790	840	880	925
WD450 WD450SM	247	370	420	475	520	560	625	685	800	900	1060	1185	1300	1400	1485	1560	1630

# UNIVERSAL STYLE STEAM TRAPS

# WD600LSM-HP

High-Pressure Thermodynamic **Steam Trap Module** (mounts to Universal Connectors)

Model	<b>WD600LSM-HP</b> (Side Mount Style)
Connections	<b>Fits WU450 Series Universal Connectors</b>
Body Material	<b>Stainless Steel</b>
PMO Max. Operating Pressure	<b>600 PSIG</b>
TMO Max. Operating Temperature	<b>750°F</b>
PMA Max. Allowable Pressure	<b>720 PSIG @ 100°F</b>
TMA Max. Allowable Temperature	<b>800°F @ 600 PSIG</b>



**WD600LSM-HP**  
**HIGH PRESSURE**  
**Thermodynamic**  
**Steam Trap Module**  
(Side Mount Style)

Units: Inches

Steam trap modules can be used with other manufacturers' Universal Connectors.

## TYPICAL APPLICATIONS

**DRIP, TRACER:** The **WD600LSM-HP** steam trap module mounted to a universal connector can be used anywhere conventional thermodynamic steam traps are used. Used on drip, tracing and light process applications where removal of air is not critical. The **WD600LSM-HP** trap module mounts to any Universal Connector.

## HOW IT WORKS

The universal connector is permanently installed into the pipeline where the steam trap would normally be placed. The trap module is bolted to the universal connector with two bolts and sealed with two gaskets. When a new trap module is needed, it can be easily removed and replaced with a standard open-end or socket wrench without disturbing the existing piping.

## FEATURES

- Trap module can be easily removed and replaced in minutes without having to disconnect any piping
- Trap modules can be used with most manufacturers' 2-bolt universal connector
- All stainless steel construction with hardened seat

## SAMPLE SPECIFICATION

The steam trap module shall be designed to attach to the industry standard two-bolt universal connector. Trap module shall be of a thermodynamic design. Universal connector shall conform to the two bolt industry standard with integral strainer and blowdown options.

Model	CAPACITIES – Condensate (lbs/hr)					
	Differential Pressure (PSI)					
	150	200	250	300	450	600
<b>WD600LSM-HP</b>	465	500	550	600	675	730

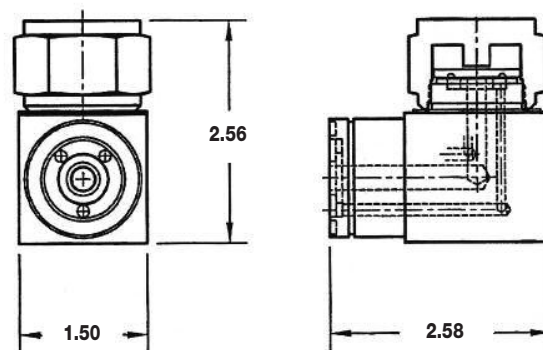

**WD600LSM-HP Thermodynamic**  
**Steam Trap Module**

## INSTALLATION

Isolation valves should be installed before and after the universal connector to facilitate maintenance. Trap module is attached to the connector using two bolts and two sealing gaskets.

## MAINTENANCE

If the trap fails for any reason, replace only the trap module. If universal connector is equipped with an integral strainer it should be cleaned periodically. For full maintenance details see Installation and Maintenance Manual.

## OPTIONS

Universal Connectors are available with an integral strainer and blowdown valve. Connector is purchased separately. See the Universal Connectors section for more information.

## MATERIALS

Body	Stainless Steel, AISI 420
Disc	Stainless Steel, AISI 420
Cap	Stainless Steel, AISI 416
Insulation Cover	Stainless Steel, AISI 304
Bolts	Steel, ASTM A193 GR B7
Gaskets (2)	Spiral Wound 304 Stainless Steel with Grafoil Filler

# UNIVERSAL STYLE STEAM TRAPS

## WT450

Watson McDaniel reserves the right to change the designs and/or materials of its products without notice.  
©2010 Watson McDaniel Company

Thermostatic **Steam Trap Module** (mounts to Universal Connectors)

Model	<b>WT450</b>
Connections	<b>Fits WU450 Series Universal Connectors</b>
Body Material	<b>Stainless Steel</b>
PMO Max. Operating Pressure	<b>450 PSIG</b>
TMO Max. Operating Temperature	<b>Saturated Steam Temp.</b>
PMA Max. Allowable Pressure	<b>720 PSIG @ 100°F</b>
TMA Max. Allowable Temperature	<b>800°F @ 400 PSIG</b>

Steam trap modules can be used with other manufacturers' Universal Connectors.



**WT450  
Thermostatic  
Steam Trap  
Module**

### TYPICAL APPLICATIONS

**DRIP, TRACER, PROCESS:** The WT450 steam trap module mounted on a universal connector can be used anywhere conventional thermostatic steam traps are used. Used on drip, tracing and light process applications. The WT450 trap module mounts to any universal connector.

### HOW IT WORKS

The universal connector is permanently installed into the pipeline where the steam trap would normally be placed. The trap module is bolted to the universal connector with two bolts and sealed with two gaskets. When a new trap module is needed, it can be easily removed and replaced with a standard open-end or socket wrench without disturbing the existing piping.

### FEATURES

- Trap module can be easily removed and replaced in minutes without having to disconnect any piping
- Trap modules can be used with most manufacturers' 2-bolt universal connector
- All stainless steel construction with hardened seat

### SAMPLE SPECIFICATION

The steam trap module shall be designed to attach to the industry standard two-bolt universal connector. Trap module shall be of a thermostatic design. The universal connector shall conform to the two-bolt industry standard with integral strainer and blowdown options.

### INSTALLATION

Isolation valves should be installed before and after the universal connector to facilitate maintenance. Trap module is attached to the connector using two bolts and two sealing gaskets.

### MAINTENANCE

When a new trap module is needed, it can be easily removed and replaced with a standard open-end wrench without disturbing the existing piping. If the universal connector is equipped with an integral strainer it should be cleaned periodically. For full maintenance details see Installation and Maintenance Manual.

### OPTIONS

Universal Connectors are available with an integral strainer and blowdown valve. Connector is purchased separately. See the Universal Connectors section for more information.

### MATERIALS

Body	Stainless Steel, AISI 420
Thermal Element	Stainless Steel, AISI 302
Disc & Seat	Stainless Steel, AISI 420
Insulation Cover	Stainless Steel, AISI 304
Bolts	Steel, ASTM A193 GR B7
Gaskets (2)	Spiral Wound 304 Stainless Steel with Grafoil Filler

### CAPACITIES – Condensate (lbs/hr)

Model	Orifice Size	Steam Inlet Pressure (PSIG)												
		5	10	20	50	100	125	150	200	250	300	350	400	450
WT450	3/16"	441	625	882	1391	1827	1969	2095	2305	2483	2636	2777	2903	3019

Note: 5/64" low capacity orifice is available upon request.

Back Pressure as Percentage of Inlet Pressure	10	20	25	30	40	50	60	70	80	90
Percent Decrease in Trap Capacity	0	0	0	2	5	12	20	30	40	55

# UNIVERSAL STYLE STEAM TRAPS

# WB450

## Bi-Metallic Steam Trap Module (mounts to Universal Connectors)

Model	<b>WB450</b>
Connections	<b>Fits WU450 Series Universal Connectors</b>
Body Material	<b>Stainless Steel</b>
PMO Max. Operating Pressure	<b>450 PSIG</b>
TMO Max. Operating Temperature	<b>662°F</b>
PMA Max. Allowable Pressure	<b>720 PSIG @ 100°F</b>
TMA Max. Allowable Temperature	<b>800°F @ 400 PSIG</b>

Steam trap modules can be used with other manufacturers' Universal Connectors.



**WB450  
Bi-Metallic  
Steam Trap  
Module**

### TYPICAL APPLICATIONS

The **WB450** Series Bi-Metallic Module is used in steam tracing applications (process lines, instrumentation and winterization, general steam jacketing) and small process applications where accurate control of condensate discharge temperature is required to provide maximum usage of energy.

### HOW IT WORKS

Bi-Metallic plates of dissimilar metals respond to steam temperature variations, whereby the metals are relaxed at relatively cool conditions, such as start-up, and the trap is open for the discharge of condensate. As temperature nears the preset subcool temperature below saturation, the metals react and expand, closing the trap and preventing the loss of live steam. Field adjustability of the bimetal element allows precise control of the condensate discharge temperature.

### FEATURES

- Excellent for various steam tracing and small process applications where maximum energy usage is desired
- Field-adjustable bimetal element allows precise control of condensate discharge temperature, providing maximum use of additional energy in the condensate
- Internal screen and seat/plug design help prevent pipe scale and debris from accumulating on seating surfaces to provide trouble-free operation

### MATERIALS

Body and Cover	Stainless Steel, A-351, Gr. CF8
Bimetal Element	GB14
Valve Seat	420 Stainless Steel
Gaskets (2)	Spiral Wound 304 Stainless Steel with Grafoil Filler
Valve Stem	Stainless Steel with Grafoil Filler

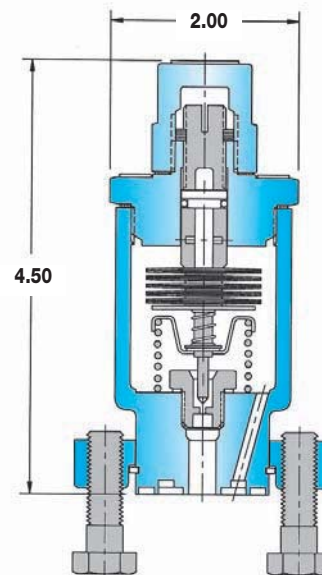

Units: Inches

**Maximum Trap Capacities at Various Inlet Pressures and Set Temperatures – Condensate (lbs/hr)**

Set Temperature	Steam Inlet Pressure (PSIG)											
	15	30	50	100	125	150	200	250	300	350	400	450
<b>220°F</b>	56	70	102	144	161	177	204	228	250	270	289	306
<b>240°F</b>	116	164	212	300	336	368	425	475	520	562	600	637
<b>260°F</b>	134	190	245	346	387	424	490	548	600	648	693	735
<b>280°F</b>	143	202	261	370	413	453	523	584	640	691	739	784

- Notes:**
- 1) Capacities in chart are based on discharging condensate to atmosphere with a condensate temperature of 200° F.
  - 2) Maximum discharge capacity up to 970 lbs/hr, depending on operating condition requirements.
  - 3) Contact factory for additional information including other condensate set and discharge temperatures.
  - 4) To ensure proper operation and eliminate possible steam loss, the Set Temperature should be lower than 27 °F subcool (degrees below inlet steam saturation temperature).

# UNIVERSAL STYLE STEAM TRAPS

## 450 Series

Watson McDaniel reserves the right to change the designs and/or materials of its products without notice.  
©2010 Watson McDaniel Company

### WT450 & WD450 Steam Traps with Universal Connectors - Dimensions

#### WT450 Trap Module with Universal Connectors

Connectors available in 1/2", 3/4" and 1" sizes in NPT and Socket-Weld Connections

Note: Optional Flange units available.

Units: inches

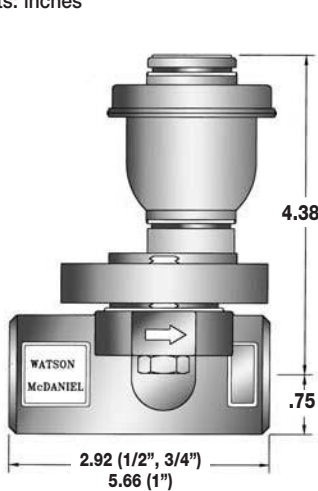

WT450 Trap Module with WU450 Connector

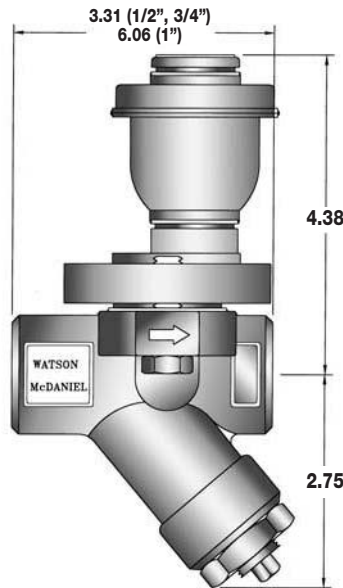

WT450 Trap Module with WU450S Connector (Strainer)

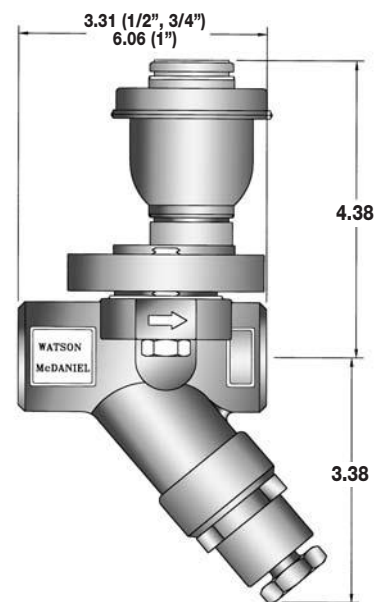

WT450 Trap Module with WU450SB Connector (Strainer & Blowdown)

#### WD450 Trap Module with Universal Connectors

Connectors available in 1/2", 3/4" and 1" sizes in NPT and Socket-Weld Connections

Note: Optional Flange units available.

Units: inches

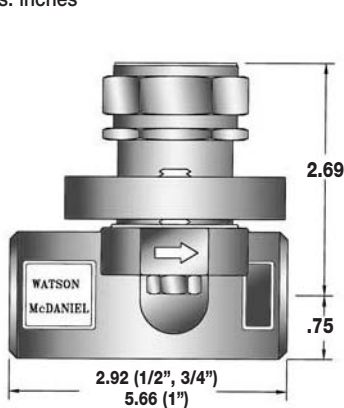

WD450 Trap Module with WU450 Connector

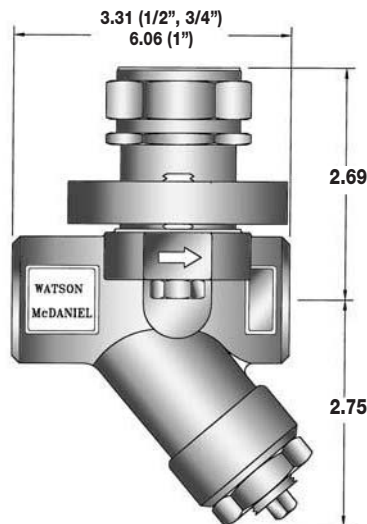

WD450 Trap Module with WU450S Connector (Strainer)

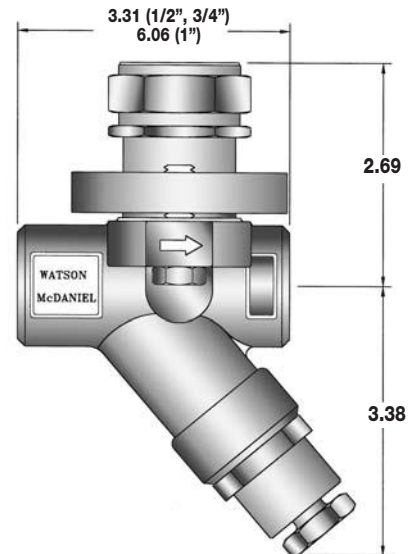

WD450 Trap Module with WU450SB Connector (Strainer & Blowdown)

# 450 Series

## WSIB450 Steam Traps with Universal Connectors - Dimensions

**WSIB450 Trap Module with Universal Connectors**  
 Connectors available in 1/2", 3/4" and 1" sizes in NPT or Socket-Weld Connections

Note: Optional Flange units available.

Units: inches

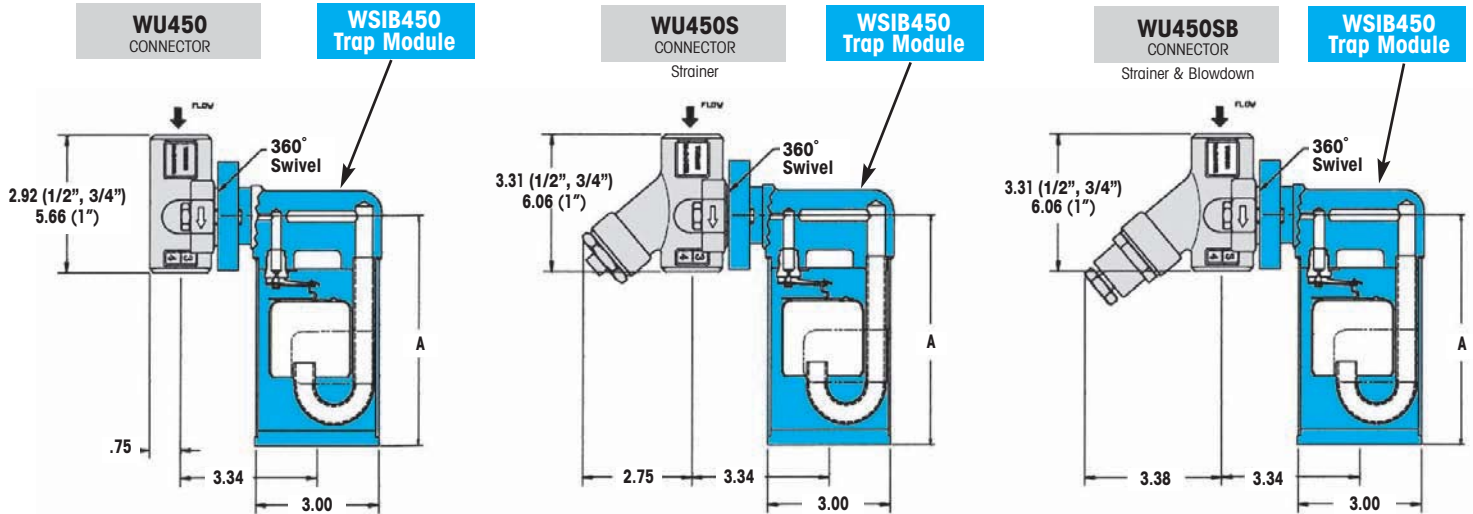

**WSIB450** A-Dimension = 5.81"  
**WSIB450H** A-Dimension = 6.81"

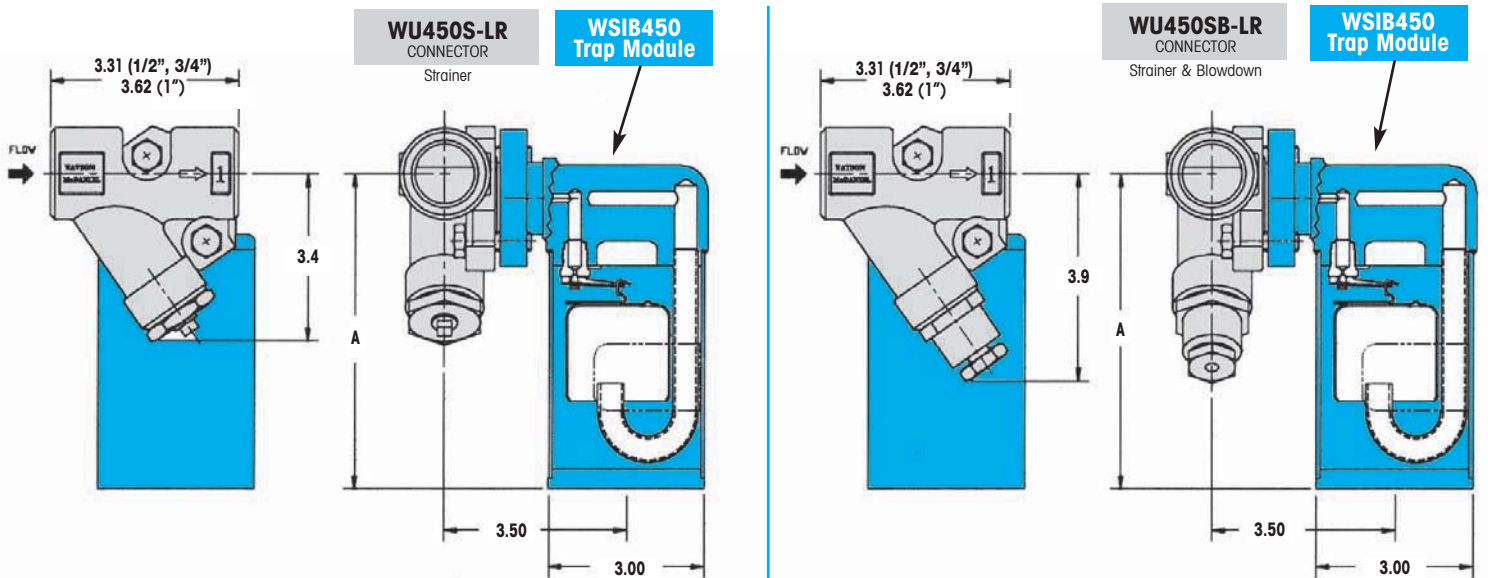

**WSIB450** A-Dimension = 6.12"  
**WSIB450H** A-Dimension = 7.12"

# UNIVERSAL STYLE STEAM TRAPS

## 450 Series

### WFT450 Steam Trap Modules with Universal Connectors - Dimensions

Watson McDaniel reserves the right to change the designs and/or materials of its products without notice.  
©2010 Watson McDaniel Company

#### WFT450 Trap Module with Universal Connectors

Connectors available in 1/2", 3/4" and 1" sizes in NPT or Socket-Weld Connections

Note: Optional Flange units available.

Units: inches

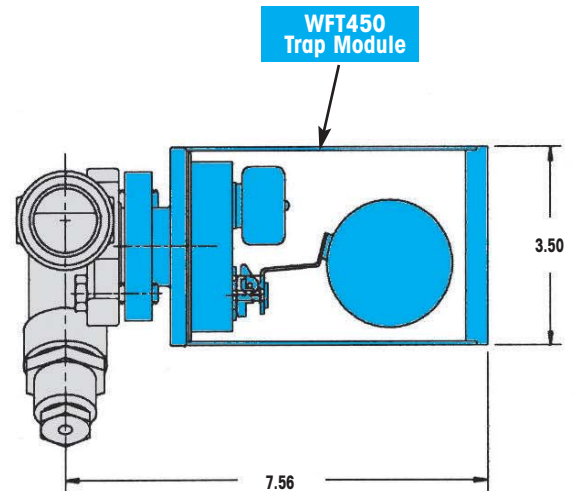
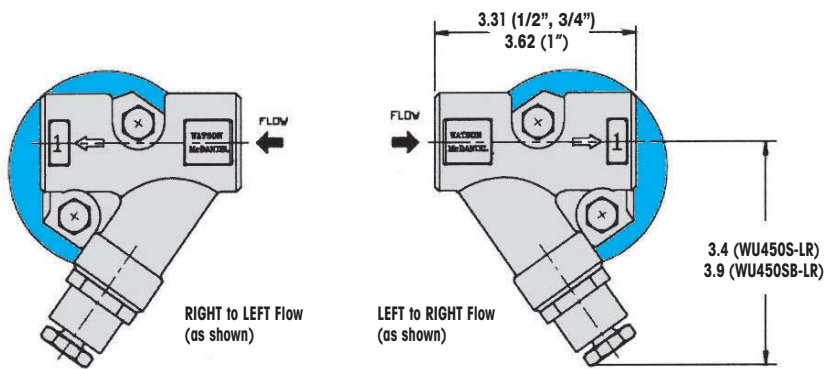
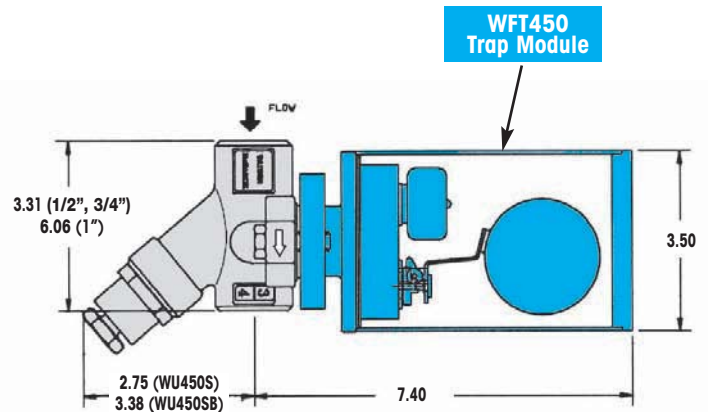
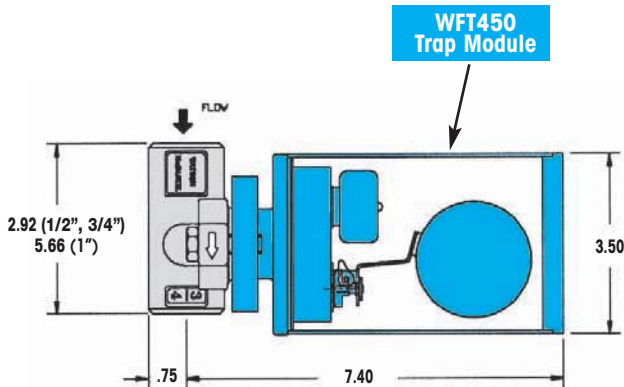

# 450 Series

WD450SM/  
WB450 & WD600LSM-HP Steam Trap Modules with Universal Connectors - Dimensions

## WB450 Trap Module with Universal Connectors

Connectors available in 1/2", 3/4" and 1" sizes in NPT and Socket-Weld Connections

Note: Optional Flange units available.

Units: inches

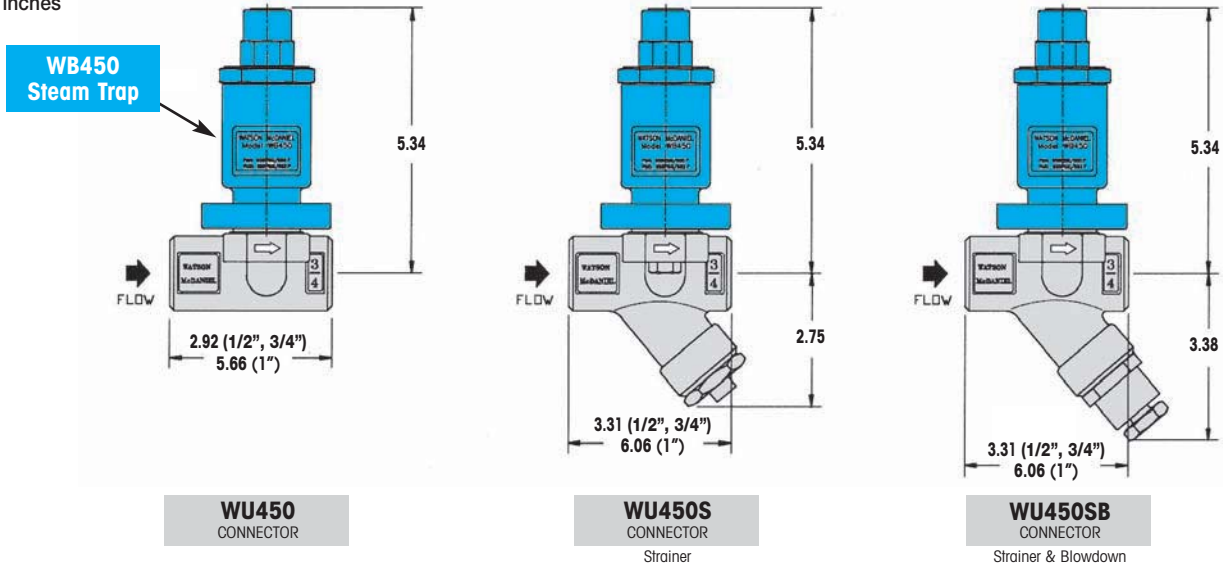

## WD450SM & WD600LSM-HP Trap Module with Universal Connectors

Connectors available in 1/2", 3/4" and 1" sizes in NPT and Socket-Weld Connections

Note: Optional Flange units available.

Units: inches

